

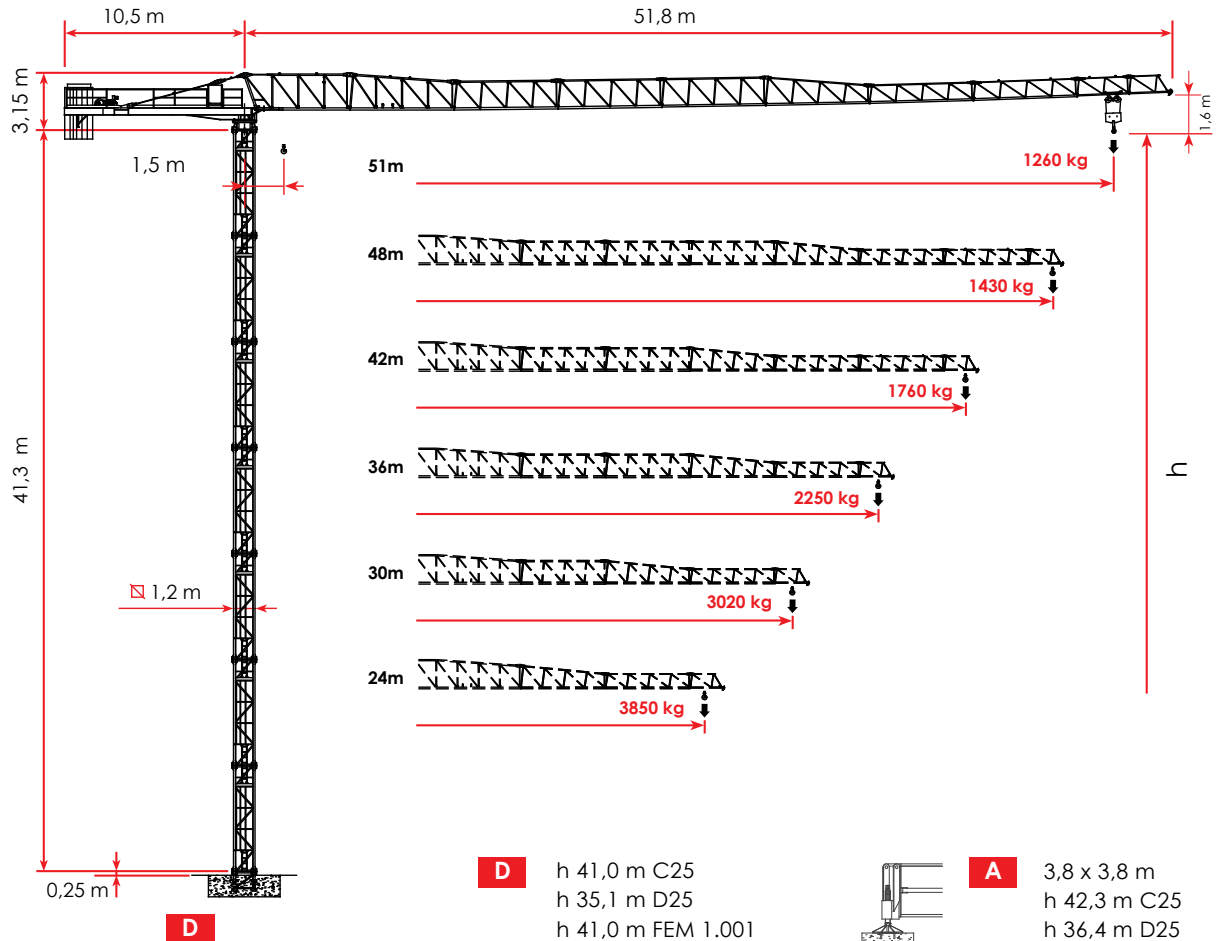

The Raimondi MRT84 at work in Winchester City erected by Bennetts Tower Cranes at a 30 meter tower height with a 30 meter jib length and five tonne maximum capacity

 **RAIMONDI**[®] MRT84
SINCE 1863



D h 41,0 m C25
h 35,1 m D25
h 41,0 m FEM 1.001

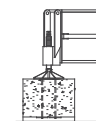

A 3,8 x 3,8 m
h 42,3 m C25
h 36,4 m D25
h 42,3 m FEM 1.001



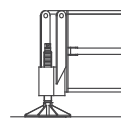
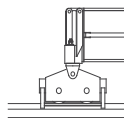











B 3,8 x 3,8 m
h 42,0 m C25
h 36,1 m D25
h 42,0 m FEM 1.001



E 3,8 x 3,8 m
h 41,7 m C25
h 35,8 m D25
h 41,7 m FEM 1.001



A4 EN 14439 C25 D25 - FEM 1.001

	IT	EN	F	DE	RU
	Altezza sotto gancio	Height under hook	Hauteur sous crochet	Höhe unter dem Haken	Высота под крюком
	Contrappesi	Counter weight jib ballast	Lest de contre-flèche	Gegenauslegerballast	Противовесы
	Freccia	Jib	Flèche	Kranarm	стрела крана
	Carico massimo	Max load	Charge maximale	Maximale Belastung	максимальная нагрузка
	Curva di carico Ultralift	Load diagrams with ultralift control	Courbes de charges Ultralift	Lastkurven Ultralift	Кривой Груз Ultralift
	Altezza libera	Free Standing	Hauteur libre	Freistehend	Свободностоящая высота
	Azionamenti	Mechanisms	Mécanismes	Antriebe	Приводы
	Velocità	Speed	Vitesse	Geschwindigkeit	скорость
4* - 5*	Marce con velocità proporzionale al carico	5 step with speed proportional to the load	5 rapports avec une vitesse proportion- nelle à la charge	5 Gang Geschwindi- gkeit proportional zum Last	Автоматический выбор скорости механизма подъема в зависимости от величины груза
	Tiro a 2 funi	Two - rope pull	Tir à deux câbles	Zug an zwei Seilen	Двукратная запасовка тросов
	Tiro a 4 funi	Four - rope pull	Tir à quatre câbles	Zug an vier Seilen	Четырехкратная запасовка тросов
	Totale metri fune tamburo	Total meters rope drum	Total des mètres de corde du tambour	Total Meter Seil Trommel	Запас троса на барабане в метрах
	Diametro fune	Rope diameter	Diamètre du câble	Seildurchmesser	Диаметр троса
	Rotazione	Slewing	Orientation	Schwenken	Поворот
	Carrello	Trolley	Chariot	Katzfahnen	Тележка

MRT84

STANDARD 2,5t

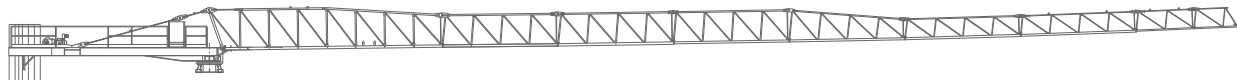

	▲▲▲▲	MAX	24 m	30 m	36 m	42 m	48 m	51 m
	m	2,5 t						
12050	51	30,0	2500	2473	2020	1699	1459	1375
11460	48	30,1	2500	2500	2081	1740	1485	
9256	42	31,0	2500	2500	2104	1760		
7934	36	33,0	2500	2500	2310			
6612	30	30,0	2500	2500				
5730	24	24,0	2500					



400 V ± 5% 50 Hz



2000 / 14 / CE

5,0 t 30 hp 22 kW

	STEP				
		m/min	kg	m/min	kg
240 m	1	7,6	2500	3,8	5000
50 kVA	2	23	2500	11,5	5000
Ø 11 mm	3	38	2500	19	5000
	4	61	1250	30,5	2500
	5	76	850	38	1700
	5*	91	400	45,5	800

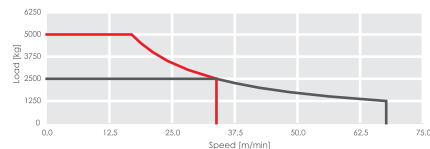

* **Speed automatically controlled by a current sensor** / Velocità regolata automaticamente da sensore di corrente / Vitesse réglée automatiquement par capteur de courant / Automatisch durch stromsensor geregelte geschwindigkeit / скорость АВТОМАТИЧЕСКИ КОНТРОЛИРУЕТСЯ ДАТЧИКОМ НАПРЯЖЕНИЯ



0,37/ 0,7/ 1,0 min⁻¹ • 4 kW /





14,0/ 39,0/ 63,0/ 79,0 (1) m/min • 3,6 kW /



14 m/min • 2 x 2,9 kW



MRT84 - 2,5 / 5,0t

JIB	24	30	36	42	48	51
1,5 ▶	18,5	18,0	17,0	16,0	16,0	14,0
14	5000	5000	5000	5000	5000	5000
16	5000	5000	5000	5000	5000	4810
18	5000	5000	4893	4606	4416	4221
20	4706	4735	4357	4099	3929	3754
22	4238	4263	3920	3687	3533	3374
24	3850	3873	3559	3346	3205	3060
28		3263	2995	2813	2692	2569
30		3020	2771	2601	2489	2373
32			2575	2416	2311	2203
34			2403	2253	2155	2053
36			2250	2109	2016	1920
40				1865	1781	1695
42				1760	1680	1599
44					1589	1511
46					1506	1432
48	+ 50 kg				1430	1359
51						1260

ULTRALIFT If the crane is not equipped with Ultralift control, all intermediate loads are decreased by 10% / Senza il sistema Ultralift tutte le portate intermedie diminuiscono il carico del 10% / Les charges intermediaires sont diminuées de 10% si la grue n'est pas équipé d'un controle Ultralift. / Mit dem ULTRALIFT-System erhöhen alle Zwischenbelastbarkeiten die Last um 10% / Без ULTRALIFT промежуточный вес уменьшается на 10%.

□ 1,2 m L = 3,8 m **A**

□ 1,2 m L = 3,8 m **B**

□ 1,2 m L = 3,8 m **E**

□ 1,2 m **D**

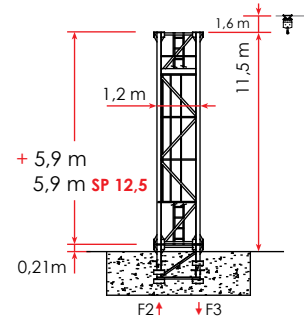
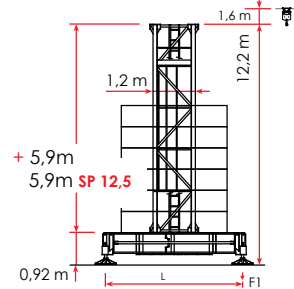
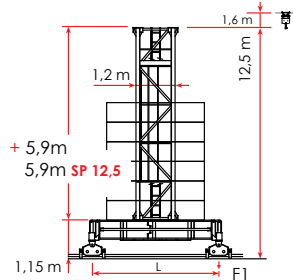
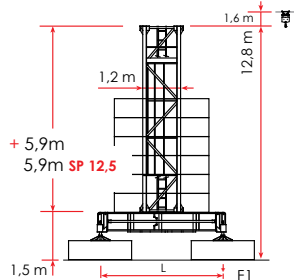

A	Base on concrete pads	Base su zatteroni	Grue sur blocs d'appui	Kran auf Stützblöcken	Кран на опорных блоках
B	Travelling base	Base traslante	Grue à traslation	Fahrbarer Kran	Кран передвижной
E	Base on steel pads	Base con piedi regolabili	Grue sur pieds réglables	Kran auf verstellbaren Füßen	Кран на регулируемых лапах
D	Crane on embedded	Gru su fronchetto	Grue sur plinthe	Kran auf Fundamentplatte	Кран на фундаменте

A

□ 1,2 m - L = 3,8 m



EN 14439 - C25



EN 14439 - D25









FEM 1.001







	ΔH (m)	H (m)	Z** (t)	F1 (kN)		ΔH (m)	H (m)	Z** (t)	F1 (kN)		ΔH (m)	H (m)	Z** (t)	F1 (kN)
7	-	-	-	-		7	-	-	-		7	-	-	-
6	-	-	-	-		6	-	-	-		6	-	-	-
5	5,9	42,3	89,1	737		5	-	-	-		5	5,9	42,3	59,4 595
4	5,9	36,4	69,3	517		4	5,9	36,4	89,1 731		4	5,9	36,4	49,5 478
3	5,9	30,5	59,4	402		3	5,9	30,5	69,3 489		3	5,9	30,5	49,5 394
2	5,9	24,6	59,4	371		2	5,9	24,6	49,5 354		2	5,9	24,6	39,6 341
+1	5,9	18,7	59,4	350		+1	5,9	18,7	39,6 300		+1	5,9	18,7	39,6 323

B
 1,2 m - L = 3,8 m

STANDARD 1,2 CITY 5t





  EN 14439 - C25					  EN 14439 - D25					  FEM 1.001				
ΔH (m)	H (m)	Z** (t)	F1 (kN)		ΔH (m)	H (m)	Z** (t)	F1 (kN)		ΔH (m)	H (m)	Z** (t)	F1 (kN)	
7	-	-	-	-	7	-	-	-	-	7	-	-	-	-
6	-	-	-	-	6	-	-	-	-	6	-	-	-	-
5	5,9	42,0	89,1	735	5	-	-	-	-	5	5,9	42,0	59,4	576
4	5,9	36,1	69,3	515	4	5,9	36,1	89,2	731	4	5,9	36,1	49,5	461
3	5,9	30,2	49,5	378	3	5,9	30,2	69,3	487	3	5,9	30,2	49,5	386
2	5,9	24,3	39,6	324	2	5,9	24,3	59,4	382	2	5,9	24,3	39,6	337
+1	5,9	18,4	39,6	303	+1	5,9	18,4	59,4	352	+1	5,9	18,4	39,6	321

E
 1,2 m - L = 3,8 m





  EN 14439 - C25					  EN 14439 - D25					  FEM 1.001				
ΔH (m)	H (m)	Z** (t)	F1 (kN)		ΔH (m)	H (m)	Z** (t)	F1 (kN)		ΔH (m)	H (m)	Z** (t)	F1 (kN)	
7	-	-	-	-	7	-	-	-	-	7	-	-	-	-
6	-	-	-	-	6	-	-	-	-	6	-	-	-	-
5	5,9	41,7	89,1	719	5	-	-	-	-	5	5,9	41,7	59,4	576
4	5,9	35,8	69,3	502	4	5,9	35,8	89,2	712	4	5,9	35,8	49,5	461
3	5,9	29,9	49,5	370	3	5,9	29,9	69,3	472	3	5,9	29,9	49,5	386
2	5,9	24,0	39,6	320	2	5,9	24,0	49,5	347	2	5,9	24,0	39,6	337
+1	5,9	18,1	39,6	299	+1	5,9	18,1	39,6	299	+1	5,9	18,1	39,6	321

Z**  **Comply with the specified ballast Z(t) / Attenersi alla zavorra indicata Z(t) / S'en tenir au lest indiqué Z(t) / Unbedingt die angegebenen Ballastwerte einhalten Z(t) / Соблюдать указанный балласт Z(t)**

STANDARD 1,2 CITY 5t

D 														
														
ΔH (m)	H (m)	F2 (kN)	F3 (kN)		ΔH (m)	H (m)	F2 (kN)	F3 (kN)		ΔH (m)	H (m)	F2 (kN)	F3 (kN)	
7	-	-	-	-	7	-	-	-	-	7	-	-	-	-
6	-	-	-	-	6	-	-	-	-	6	-	-	-	-
5	5,9	41,0	1278	1122	5	-	-	-	-	5	5,9	41,0	1023	864
4	5,9	35,1	909	759	4	5,9	35,1	1239	1089	4	5,9	35,1	733	577
3	5,9	29,2	642	508	3	5,9	29,2	844	701	3	5,9	29,2	607	479
2	5,9	23,3	568	440	2	5,9	23,3	568	440	2	5,9	23,3	543	422
+1	5,9	17,4	507	386	+1	5,9	17,4	507	386	+1	5,9	17,4	491	378

STANDARD 1,18 HC 5t

D 														
														
ΔH (m)	H (m)	F2 (kN)	F3 (kN)		ΔH (m)	H (m)	F2 (kN)	F3 (kN)		ΔH (m)	H (m)	F2 (kN)	F3 (kN)	
-	-	-	-	-	-	-	-	-	-	-	-	-	-	-
5	2,36	36,1	1241	1063	5	-	-	-	-	5	2,36	36,1	1117	957
4	2,36	33,7	1068	895	4					4	2,36	33,7	961	806
3	2,36	31,4	910	741	3	2,36	31,4	1249	1080	3	2,36	31,4	819	667
2	2,36	29,0	766	611	2	2,36	29,0	1059	895	2	2,36	29,0	689	550
+1	2,36	26,6	726	575	+1	2,36	26,6	886	725	+1	2,36	26,6	653	518
n°10	2,36	24,2			n°10	2,36	24,2			n°10	2,36	24,2		

1,5 CITY - TP 12/15 - HEM BOOSTER

TP12/15m

L = 4,5 m

E

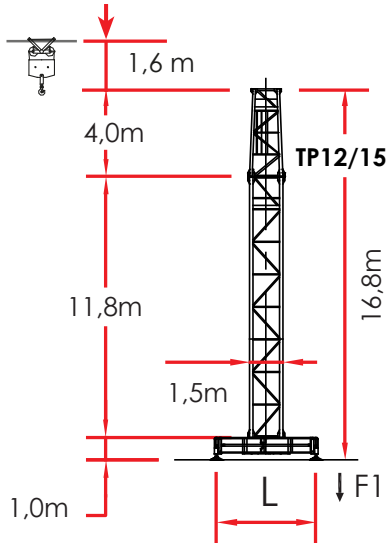

TP12/15m

HEM Booster

D

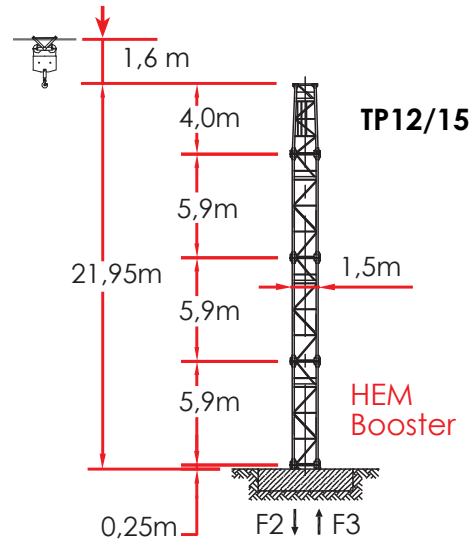

E

1,2/1,5 m - L = 4,5 m



FEM 1.001

ΔH (m) H (m) Z** (t) F1 (kN)

-	-	-	-	-
6	5,9	51,7	82,6	910
5	5,9			
4	5,9			
3	5,9			
2	5,9			
+1	5,9			

D

1,2/1,5 m HEM Booster



FEM 1.001

ΔH (m) H (m) F2 (kN) F3 (kN)

-	-	-	-	-
6	5,9	56,9	1614	1424
5	5,9			
4	5,9			
3	5,9			
2	5,9			
+1	5,9			



For different heights contact the technical department / Per altezze diverse contattare l'ufficio tecnico / Pour des hauteurs différentes contactez le département technique / Für unterschiedliche Höhen Kontakt zum Technischen / Недопустимо увеличение высоты крана без согласования с технической службой производителя



Position of next anchor to increase height under hook / Posizione prossimo ancoraggio per aumento altezza sotto gancio / Position du prochain ancrage pour augmenter la hauteur sous crochet / Lage nächste Verankerung zur Erhöhung unter dem Haken / положение для следующего якоря большей высоты под крюком



Anchor position / Posizione d'ancoraggio / Position de ancrage / Verankerungsposition / позицию анкеровки







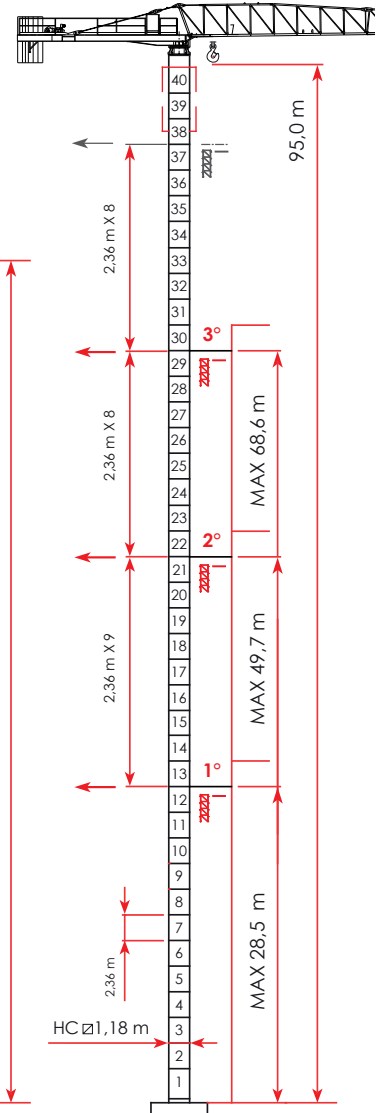
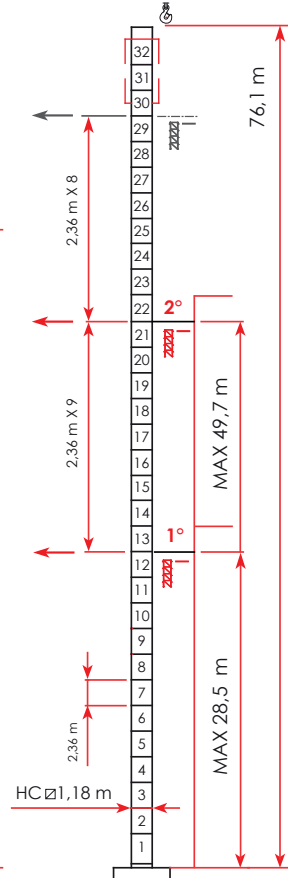
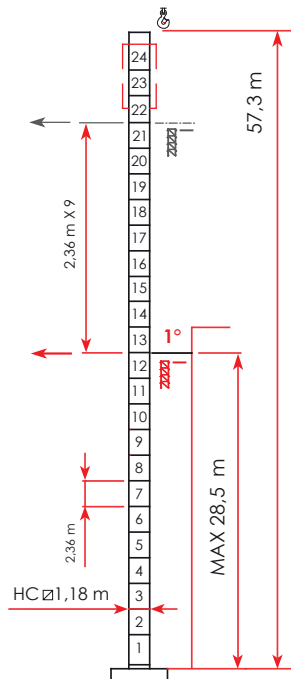
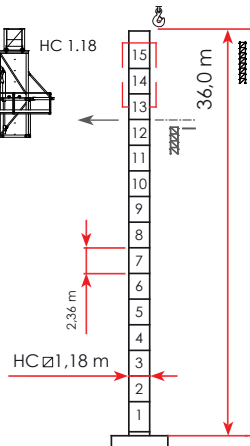
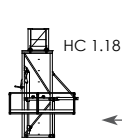







FEM 1.001

EN 14439 C25

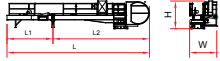

Climbing crane / Sopralzo idraulico / Téléscopage sur dalles / Kletterkrane im Gebäude / Кран поднимающийся на плитах перекрытия

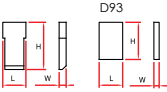
Description	Item	Pz	Drawing	Dimension (m)			Weight (kg)	
				l	w	h	Unit	Total
	n.	n°						
	1	1A		6,170	1,100	2,130	960	-
		1B		6,090	1,100	2,100	740	-
		2		6,070	1,100	1,700	670	-
		3		6,070	1,100	1,700	500	-
		4		6,010	1,100	1,700	450	-
		5		6,010	1,100	1,700	380	-
		6		5,980	1,100	1,100	370	-
		7		5,980	1,100	1,100	320	-
		8		3,070	1,100	1,100	130	-
		9		2,500	1,100	1,200	110	-
				L1 4,10	1,760	2,450	2130	-
	2	1		L2 7,87	7,870	2,400	2,450	3670
				L 11,97	2,400	2,450	5800	-
		1		3,280	1,580	2,210	890	-
		4		A75 1,250	0,300	2,865	2204	8816
	3	2		B75 1,250	0,180	2,865	1322	2644
		1		D93 0,900	0,200	1,450	590	-

Jib element

Elemento freccia





Élément de flèche



Auslegerelement jib section

Секция стрелы

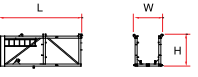
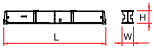
Counterjib - tournable, hoisting winch, trolley jib, electrical box / Controfreccia - girevole, argano sollevamento, quadro elettrico / Contreflèche tournante, treuil de levage, armoire électrique / Gegenausleger, Hubwinde, Laufkatze, Schaltschrank, Element für Gegengewichts Blöcke anführen / Консоль с поворотным кругом, лебедка, тележка

Counterweight block / Blocchi di contrappeso / Contre - poids / Gegengewichts Blöcke / Блоки противовеса

Description	Item	Pz	Drawing	Dimension (m)			Weight (kg)		
				l	w	h	Unit	Total	
Tower element / Elementi di torre / Elément de mature / Turmstück / Башенные секции	1	1		City 1,20	2,950	1,200	1,380	815	-
				HC1,18	2,360	1,180	1,180	870	-
				City 1,20	5,900	1,200	1,380	1610	-
				HC1,18	5,900	1,180	1,180	1850	-
Expendable foundation element / Tronchetto di fondazione / Elément a sceller / Fundamentanker / Анкер	4	1		City 1,20	11,800	1,200	1,380	2600	-
				HC 1,18	11,800	1,180	1,180	3350	-
Climbing Cage / Gabbia di montaggio / Semipoutre de chassis de base / Montagekäfig	6	1		City 1,20	1,090	1,200	1,380	476	-
				HC 1,18	1,350	1,490	1,490	790	-
Base main beam / Trave principale cro- ciera di base / Poutre de chassis de base / Haupt-träger für Kreuzbase / Главная балка крестовины основания	7	1		City 1,20	5,720	0,670	0,650	1560	-
				3,8 x 3,8 m					
Half base beam / Semitrave di base / Semipoutre de chassis de base / Halb-träg- er für Kreuzbase / Полубалка основания	8	2		City 1,20	2,770	0,450	0,665	750	1500
Concrete pad / Blocco di appoggio / Sabot en béton / Beton Fuß / Опорный блок	9	1		3,000	0,600	0,600	2464	-	

Description	Item	Pz	Drawing	Dimension (m)			Weight (kg)	
				n.	n°	l	w	h
Driving bogie / Bilancino di traslazione folle / Boggie fou / Schaukel Bewegung - Neutral- stellung / Не приводной балансир	10			0,800	0,195	0,385	190	380
Driven bogie / Bilancino di traslazione motorizzato / Boggie motoriseè / Schau- kel Bewegung - Betriebene / Приводной балансир	11			0,925	0,425	0,385	310	620
Base ballast block / Blocco di zavorra / Lest de base / Grundballast / блок балласта	12	1		^A 3,000	1,200	0,600	4953	-



3 x 13,60 m
1 x 7,00 m

MRT84 _Jib 51 m ▪ HUH 41,3 m

Top part / Parte rotante / Partie tournante / Drehender Kranteil / Поворотная часть



3 x 40 High cube
1 x 40 Open Top

Included counter weight and cabin / Cabina e contrappesi inclusi / Cabine et
 contrepoids inclus / Kabine und Gegengewichts Blöcke – inbegriffen / Противовес
 включен - кабина



www.raimondi.co



Raimondi Cranes is proudly headquartered in our ancestral home of Legnano

Corso Garibaldi, 253 • 20025 Legnano • Milan, Italy

T +39 0331 548 061 r.a. | +39 0331 545 308 r.a. | F +39 0331 450 400 | info@raimondicranes.com

DATA SHEETS REV.00.2019 / ADL



The data presented in the 2019 Product Guide is subject to change without prior notice. Being a non-binding commercial document, the reader is required to consult instruction manuals for all technical information. / I dati oggetto della presente scheda potrebbero subire

modifiche senza preavviso. Essendo un documento commerciale non vincolante si fa obbligo di consultare il manuale di istruzioni per tutte le informazioni tecniche. / Les informations données dans les fiches présentes peuvent subir des modifications sans préavis. Étant un document commercial non contraignant, il est nécessaire de consulter le manuel d'instructions pour toutes les informations techniques. / Die daten der vorliegenden blätter könnten ohne vorankündigung geändert werden. Unverbindliches Vertriebsdokument. Für technische Informationen, siehe die entsprechenden Anweisungen. / данные, указанные в настоящих спецификациях, могут изменяться без предварительного предупреждения. Этот коммерческий документ не является юридически обязательным. Для получения технической информации, см. соответствующие инструкции.